

QUICK OPERATION GUIDE

MINI-CRAWLER CRANE

MC-305C-2

Serial No. D0001 and up

WARNING

- This operation guide explains basic operation of the machine. Before starting work, always conduct checks written in “2.1 Checking Before Operation” in the separate “Operation Manual”.
For safety cautions and detailed operation of the machine not explained in this book, please read and understand the separate “Operation Manual” before operating this machine.
- This operation guide does not replace the operation manual. This is just a short helpdesk information paper to assist the trained operator of the crane with the basic operation of the crane. For complete and detailed information we refer to the operation manual of the crane.

M A E D A

CONTENTS

ITEM	Page
1. TRAVELLING AND CRANE OPERATION UNITS	3
2. INSTRUMENT PANEL SECTIONS	3
3. STARTING AND STOPPING THE ENGINE	4
4. TRAVELLING OPERATION	4
5. OUTRIGGER OPERATION	5
6. CRANE OPERATION	7
7. MOMENT LIMITER (OVERLOAD DETECTOR)	8
8. REMOTE CONTROL	9
8.1 PROCEDURE IN THE OPERATION MODE	9
8.2 OPERATION IN OUTRIGGER MODE	10
8.3 OPERATION IN CRANE MODE	11
8.4 AUTOMATIC HOOK STOW FUNCTION	11
8.5 SET-UP AND CANCEL MICRO SPEED	11
9. ELECTRIC MOTOR	11

FOR SAFE USE OF MACHINE

This manual classifies the risks into the following three categories to present the details of the safety labels in easy-to-understand manner.

DANGER

This denotes that there is an imminent hazard which will cause serious personal injury or death.

The method of hazard circumvention is stated.

WARNING

This denotes that there is a hazard which can cause serious personal injury or death.

The method of hazard circumvention is stated.

CAUTION

This denotes that there is a potential hazard which may cause minor or moderate personal injury or serious damage to this machine.

The method of hazard circumvention is stated.

This manual also provides the following to indicate what must be observed for the sake of the machine and what will be of help.

CAUTION

This denotes that failure to handle the machine properly may damage the machine or shorten its life.

NOTES

This denotes helpful information.

1. TRAVELLING AND CRANE OPERATION UNITS

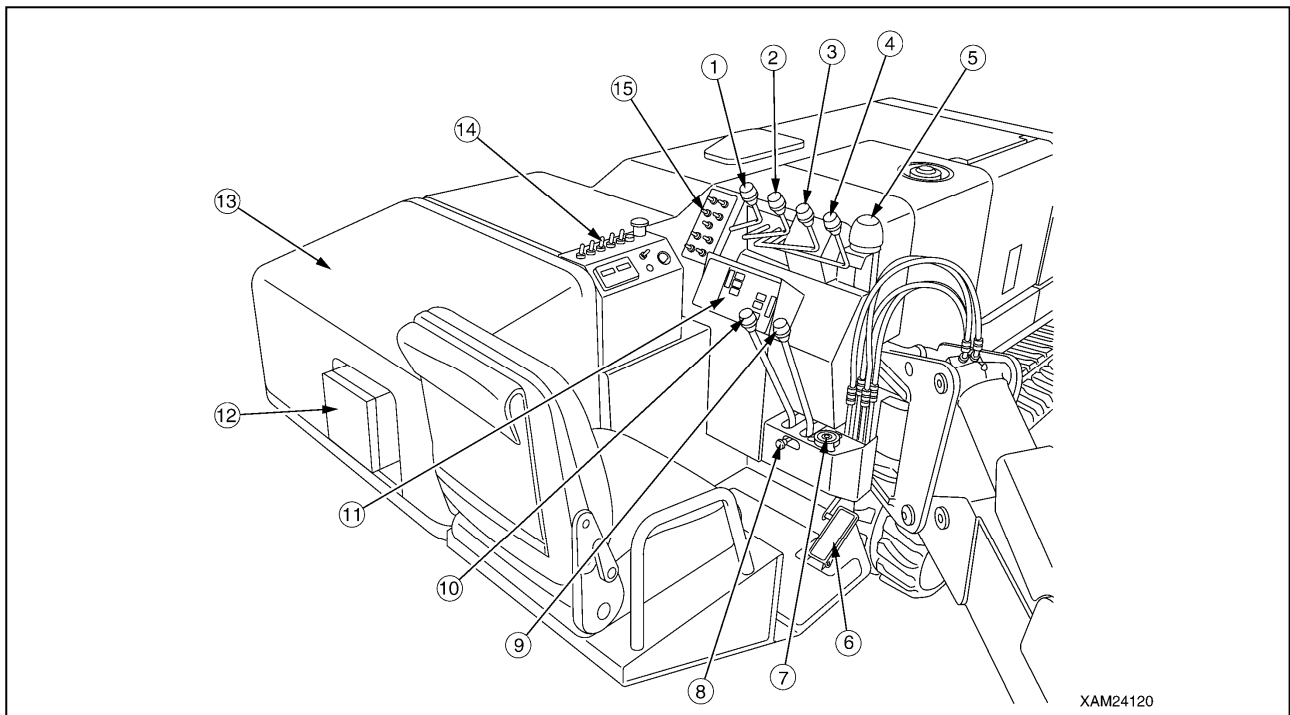

- | | | |
|-----------------------------------|----------------------------|-----------------------------------|
| (1) Slewing lever | (6) Acceleration pedal | (11) Moment limiter display panel |
| (2) Boom telescoping lever | (7) Level | (12) Power supply box |
| (3) Winch lever | (8) Travelling lock lever | (13) Power unit cover |
| (4) Boom derricking lever | (9) Right travelling lever | (14) Instrument panel |
| (5) Outrigger un-set warning lamp | (10) Left travelling lever | (15) Outrigger operation panel |

2. INSTRUMENT PANEL SECTIONS

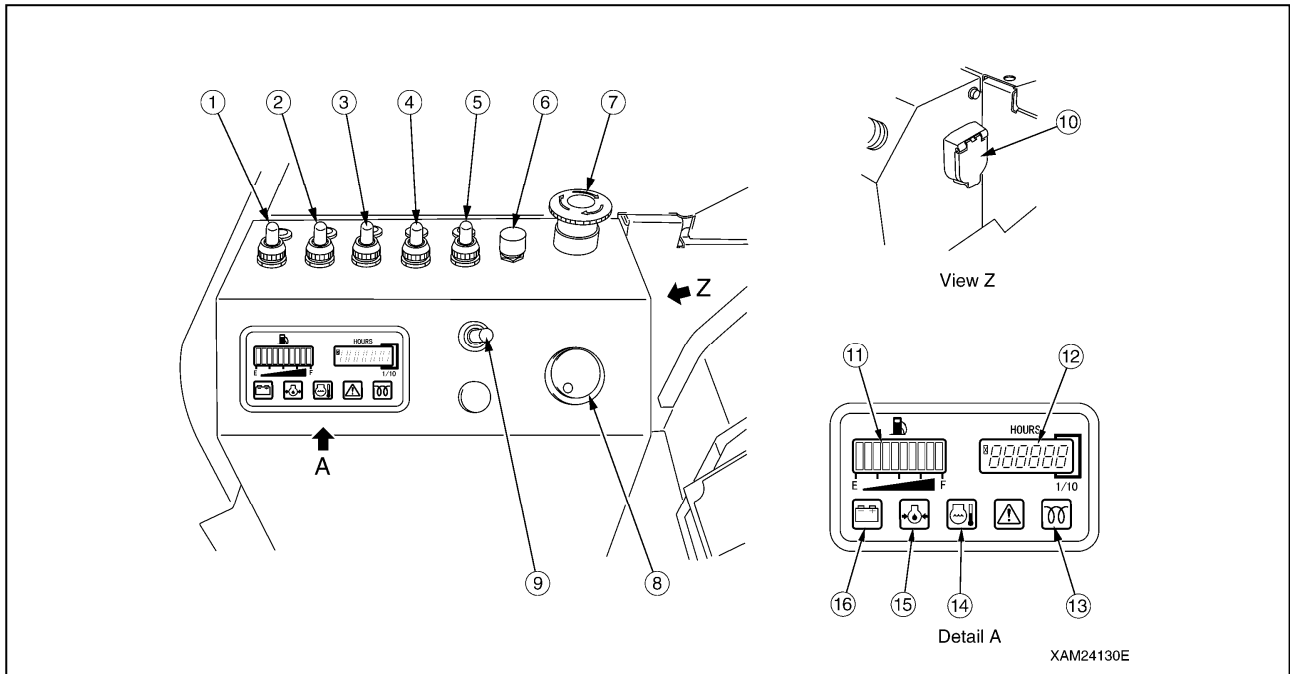

- | | | |
|----------------------------------|--------------------------------------|---------------------------------------|
| (1) Headlight switch | (7) Emergency stop switch | (12) Hour meter |
| (2) Crane high-speed switch | (8) Starter switch | (13) Pre-heat monitor |
| (3) Hook stowing switch | (9) Engine and electric motor switch | (14) Engine water temperature monitor |
| (4) Travelling high-speed switch | (MC305CRME-2 only) | (15) Engine oil pressure monitor |
| (5) Boom stowing switch | (10) Emergency stop cancel switch | (16) Battery charge monitor |
| (6) Horn switch | (11) Fuel gauge | |

3. STARTING AND STOPPING THE ENGINE

[1] STARTING THE ENGINE

1. Insert the key and turn it left (preheating) until the “preheat monitor” goes out.
2. Step on the acceleration pedal to half of it’s full stroke (medium speed).
3. Turn the key to the right to start the crane.

[2] STOPPING THE ENGINE

1. Release your foot from the acceleration pedal to change the engine speed to low idling.
2. Turn the starter switch key to the OFF position. The engine stops.

4. TRAVELLING OPERATION

[1] STARTING/MOVING MACHINE

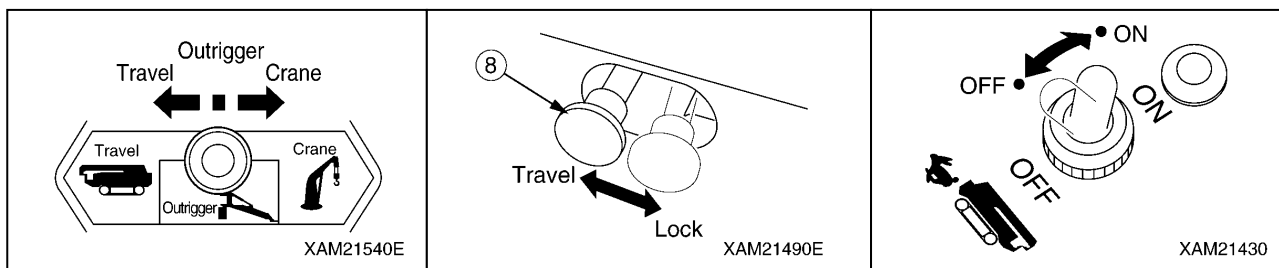

★To start travelling, operate the work selector switch to the TRAVEL position and then operate the travelling lock levers to the TRAVEL position (push to the left).

★To change travelling speed, operate the travelling high-speed switch to the ON position. The pilot lamp of the switch lights up and the machine will be in the “high-speed travelling mode”.

★To move the machine, there are two levers which work independently. The left lever operates the left rubber track, the right lever operates the right rubber track.

- To move forward, push both levers to the front.
- To move backward, pull both levers to the back.

[2] CHANGING PATH OF MACHINE

NOTES
When changing the path of the machine, always operate the travelling high-speed switch in the OFF position

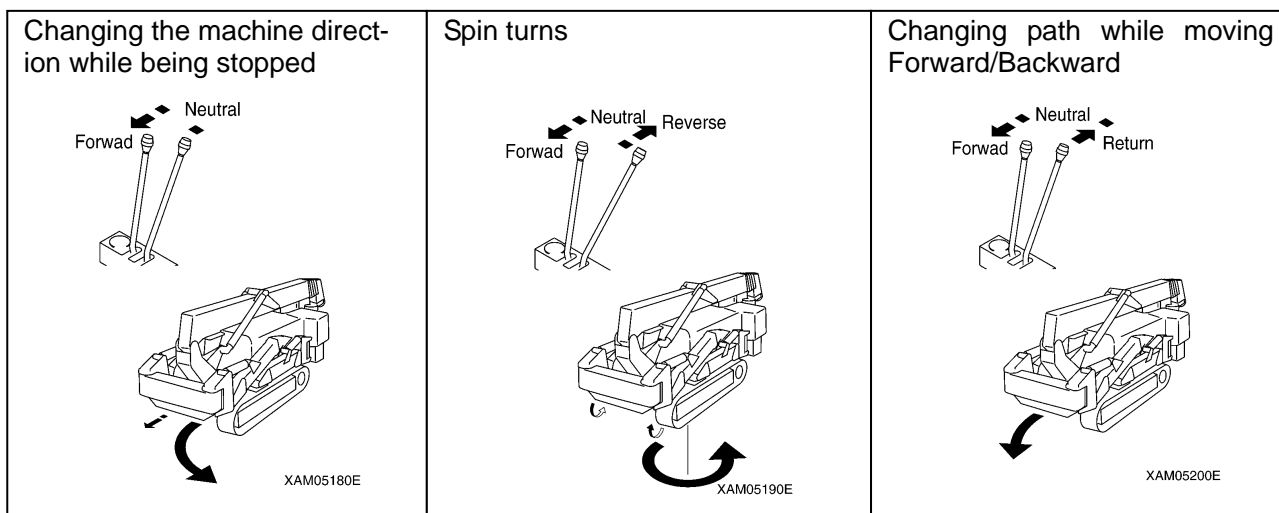

[3] STOPPING/PARKING MACHINE

Return the left and right travelling levers to the NEUTRAL position at the same time. The brakes are automatically applied and the machine will stop.

5. OUTRIGGER OPERATION

OUTRIGGER COMPONENTS

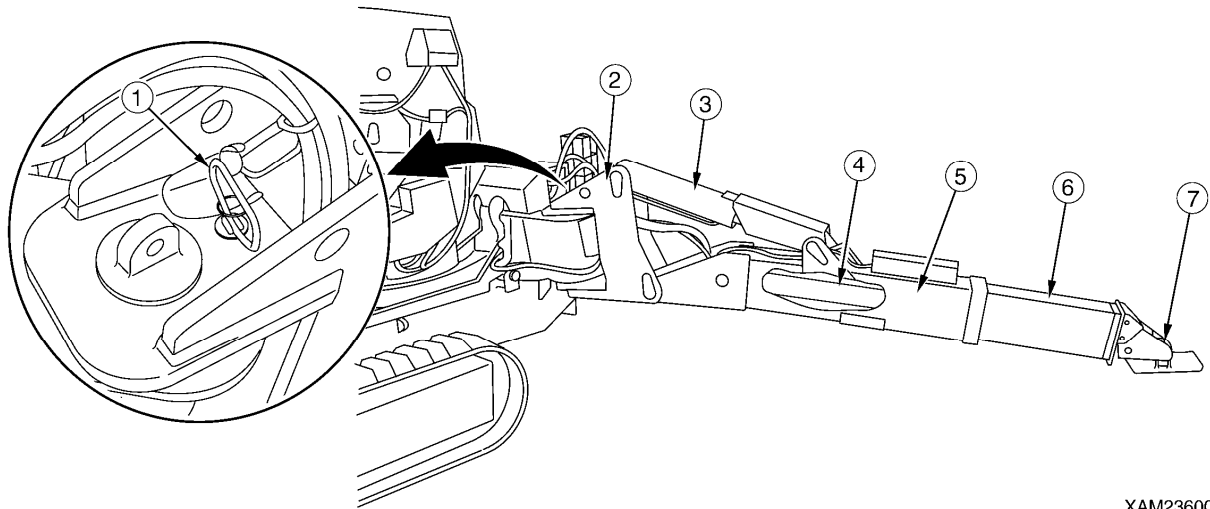

XAM23600

(1) Position pin

(2) Rotary

(3) Outrigger setting cylinder

(4) Outrigger extension cylinder

(5) Outer box

(6) Inner box

(7) Outrigger adapter (Foot)

OUTRIGGER OPERATION PANEL

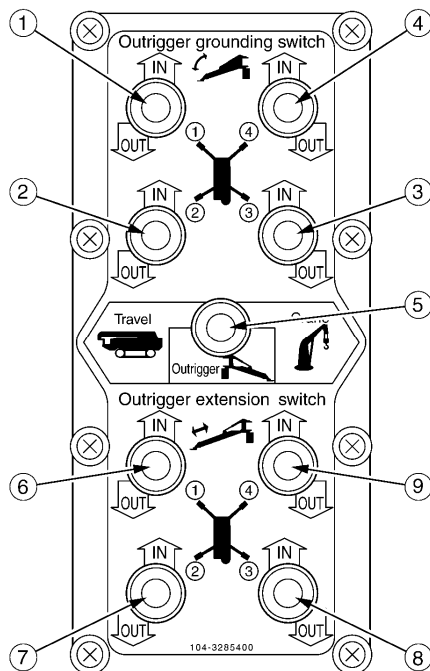

XAM21530E

(1) Outrigger (1) setting switch

(2) Outrigger (2) setting switch

(3) Outrigger (3) setting switch

(4) Outrigger (4) setting switch

(5) Work selector switch (TRAVEL, OUTRIGGER, CRANE)

(6) Outrigger (1) extension switch

(7) Outrigger (2) extension switch

(8) Outrigger (3) extension switch

(9) Outrigger (4) extension switch

★There are four outriggers installed on the machine. Although the setting method is described for just one outrigger (outrigger (4), set the other three outriggers in the same way).

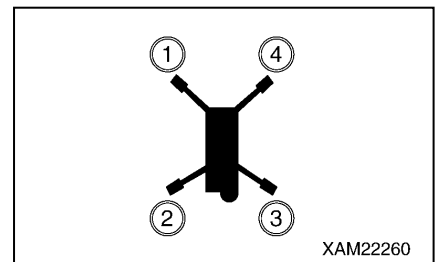

XAM22260

[1] OUTRIGGER SET UP OPERATION

⚠ WARNING

It is forbidden to work with the crane without the outriggers.

(1) TASKS TO BE PERFORMED UPON ENGINE STOP

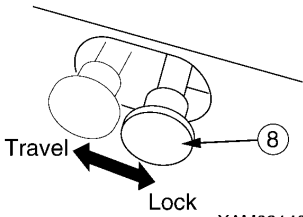
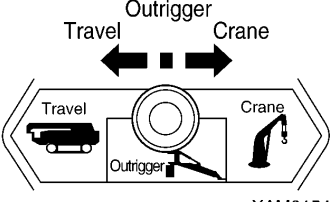
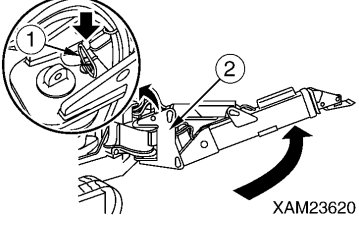
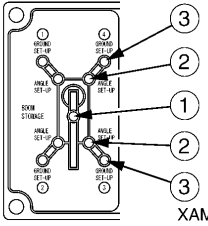
 <p>XAM22140E</p>	 <p>XAM21540E</p>	 <p>XAM23620</p>	
<ol style="list-style-type: none"> 1. Set the lock lever in "LOCK" position. 2. Operate the work selector switch to the "OUTRIGGER" position. 3. Rotate the outriggers and secure with the position pin. 4. Verify that the four outrigger extension lamps (2) (green) on the outrigger display are ON. 			 <p>XAM22010E</p>

(2) TASKS TO BE PERFORMED AFTER STARTING ENGINE

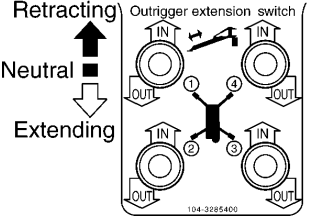
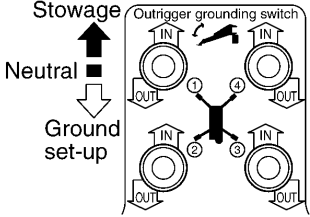
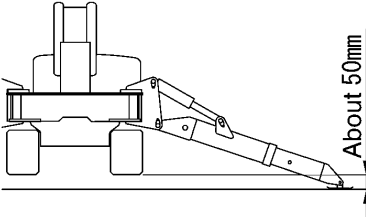
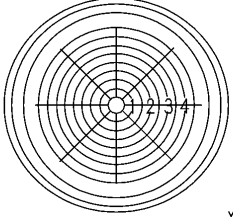
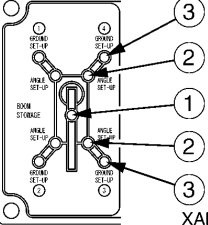
 <p>XAM21560E</p>	 <p>XAM21550E</p>	 <p>XAM05330E</p>	
<ol style="list-style-type: none"> 1. Push down outrigger extension switches and extend the outriggers as much as possible. 2. Push down outrigger setting switches and put the outriggers down ONE by ONE until they all just touch the ground. 3. Then use the outriggers TWO by TWO to stabilize the crane. 4. Check the bubble in the level in order to make sure the crane is in the correct position. 			 <p>XAM00140</p>
<ol style="list-style-type: none"> 5. Make sure the rubber tracks are about 50mm above the ground. 6. Verify that the four outrigger setting lamps (3) (green) on the outrigger display are ON. 			 <p>XAM22010E</p>

[2] OUTRIGGER STOWING OPERATION

Reverse the outrigger set up procedure to stow the outrigger.

NOTES

There are outrigger safety interlock devices.

The outriggers are not enabled if each rotary position pin is not inserted correctly and the boom is not at the stowed position. (Stowed position : the boom is fully retracted, fully down and slewed over the center of the crane until the light (1) is green)

6. CRANE OPERATION

[1] OPERATIONS BEFORE CRANE OPERATIONS

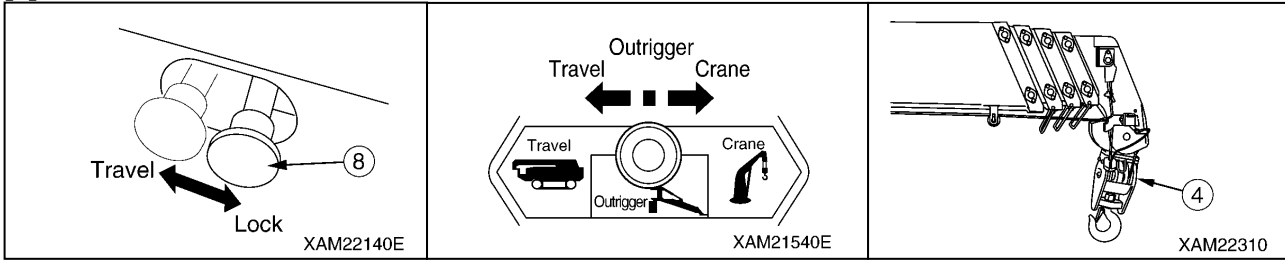

1. Set the lock lever in "LOCK" position.
2. Operate the work selector switch to the "CRANE" position
3. Operate the winch lever to the DOWN side to loosen the hook block from the stowing position.

[2] CRANE OPERATIONS

There are 4 possible crane operations :

- (1): Slewing (forward: counterclockwise, backward: clockwise)
- (2): Boom telescoping (forward: extend, backward: retract)
- (3): Hook raising and lowering
(forward: lowering, backward: raising)
- (4): Boom derricking (forward: lowering, backward: raising)

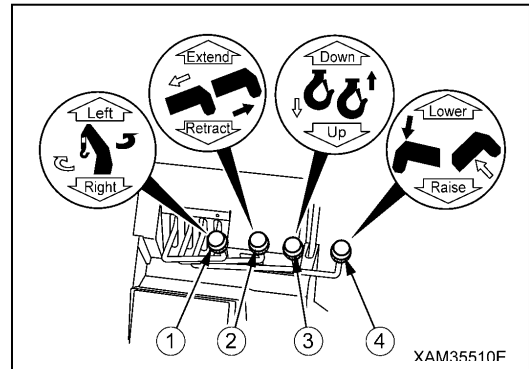

WARNING

Never let the hook block touch the ground or let the winch rope slacken. This could damage the winch rope.

NOTES

When extending the boom, always lower the hook simultaneously.

[3] CRANE STOWING OPERATION

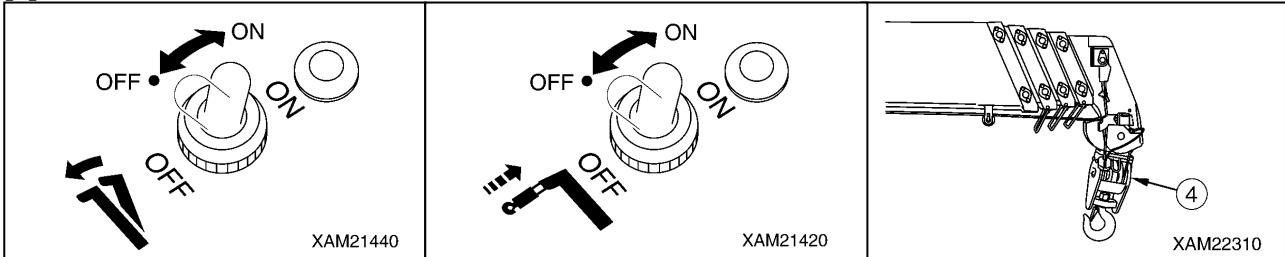

1. Completely retract the boom and slew until the boom is over the center of the crane. Lower the boom to the maximum (it stops automatically).
2. With the boom stowing switch moved to the ON position, operate the boom derricking lever again to the LOWER side to stow the boom.
3. With the hook stowing switch at the ON position, operate the winch lever to the UP side again and slowly raise the hook block to stow the block at the bottom of the boom end.
4. Verify that the boom stowing lamp (1) (green) on the outrigger display lights up.

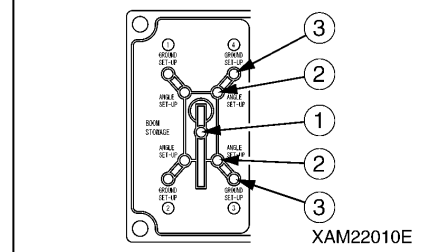

NOTES

There are crane safety interlock devices.

The crane operation is enabled only when all four outriggers are extended and grounded.

7. MOMENT LIMITER (OVERLOAD DETECTOR)

MOMENT LIMITER FUNCTIONS

[1] PROHIBITED ACTIONS AFTER AUTO STOP

⚠ DANGER

The following crane operations are prohibited after the crane has stopped automatically due to overloading. These operations may cause overturning of the machine or breakage of the boom and are very dangerous.

- Boom lowering operation
- Boom extending operation
- Hook raising operation
- Crane slewing operation

[2] OVERLOAD WARNING

1. PRE-WARNING:

“Actual load” is 90 to less than 100 % of the “rated total load”.

- The Load capacity display indicates 90%.
- The alarm bleeps intermittently.
- The working status lamp changes from green to yellow.

2. LIMIT WARNING:

“Actual load” is 100 % or higher than the “rated total load”.

- The Load capacity display indicates 100%.
- The alarm sounds continuously.
- Voice message of “Overloading” sounds.
- The working status lamp changes from yellow to red.
- The hazardous operation of the crane stops automatically.
(Hook raising, boom lowering, boom extending)

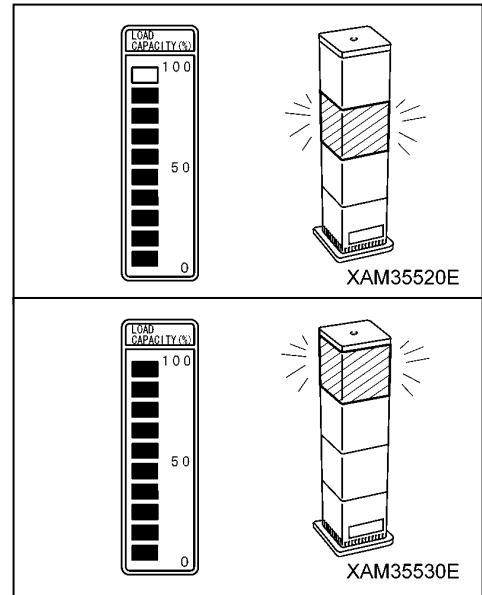

3. RECOVERY OPERATION AFTER AUTO STOP

If the system stops automatically, promptly perform one of following the recovery operation caused by overloading.

- (1) Hook lowering operation
- (2) Boom retracting operation
- (3) Boom raising operation (never raise the boom to lift the load from the ground, always winch the load clear of the ground before any other operation is performed)

MOMENT LIMITER DISPLAY

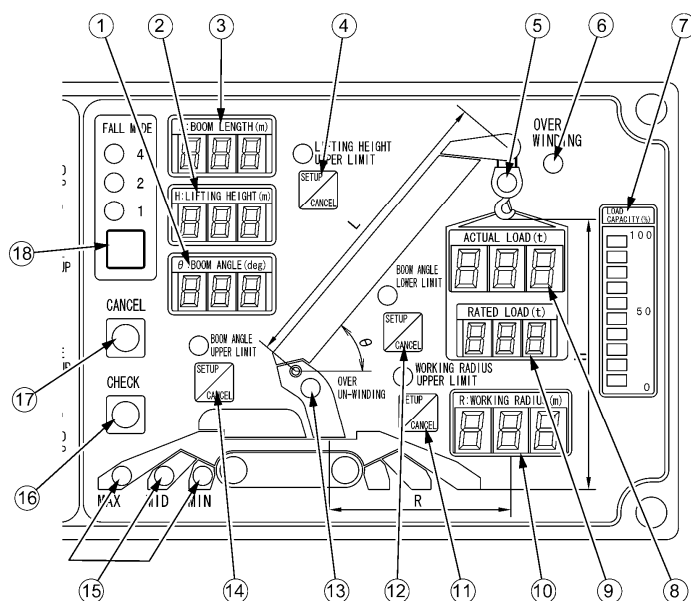

- (1) Boom angle display
- (2) Lifting height display
- (3) Boom length display
- (4) Boom lifting height upper limit switch
- (5) Load factor LED
- (6) Over hoist detection LED
- (7) Load capacity display
- (8) Actual load display
- (9) Rated total load display
- (10) Working radius display
- (11) Working radius upper limit switch
- (12) Boom angle lower limit switch
- (13) Over un-winding LED
- (14) Boom angle upper limit switch
- (15) Outrigger extension LED
- (16) Check switch
- (17) Cancel switch
- (18) Fall mode selector & searcher hook mode switch

8. REMOTE CONTROL

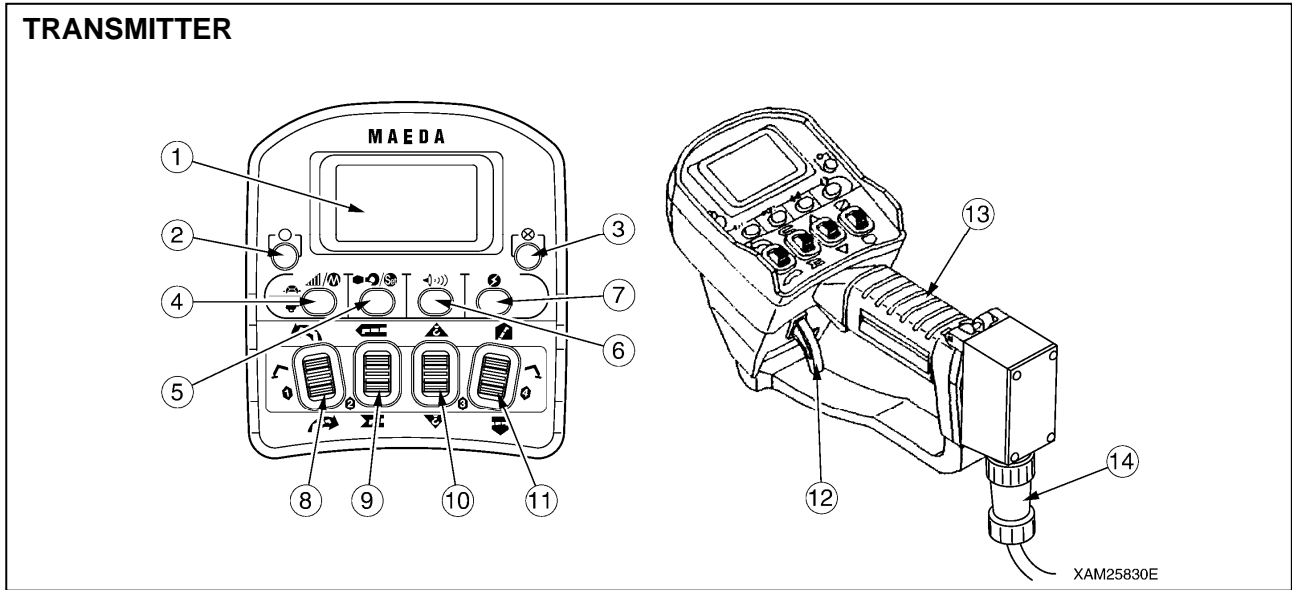

- | | |
|------------------------------|---|
| (1) LCD Screen | (8) Slewing/No.1 Outrigger Operation Lever |
| (2) Start/Reset Button | (9) Boom Telescoping/No.2 Outrigger Operation Lever |
| (3) Stop/EMO Button | (10) Hook Raising and Lowering/No.3 Outrigger Operation Lever |
| (4) Speed/Mode Button | (11) Boom derricking/No.4 Outrigger Operation Lever |
| (5) Hook Stow/Setting Button | (12) Accelerator Lever |
| (6) Horn Button | (13) Grip |
| (7) Power Switch | (14) Connection Cable |

8.1 PROCEDURE IN THE OPERATION MODE

[1] CALL UP CRANE MODE

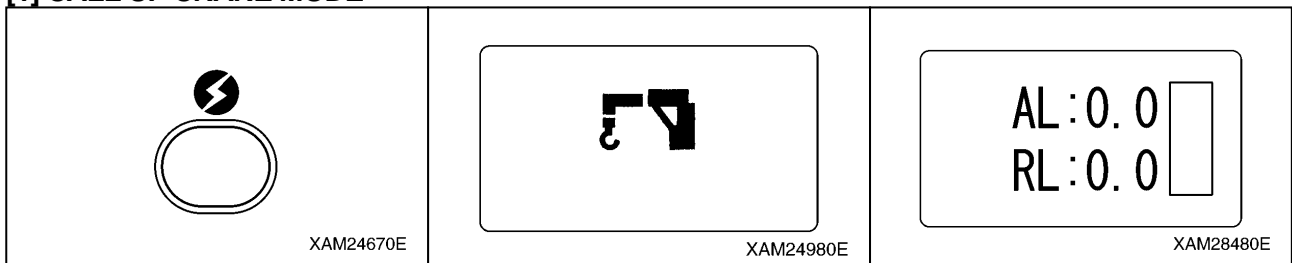

1. Push the Power button to turn ON the Transmitter.
2. The "Crane mark" is displayed in the LCD screen for about 2 seconds.
3. The crane is ready for operation.

[2] CALL UP OUTRIGGER MODE

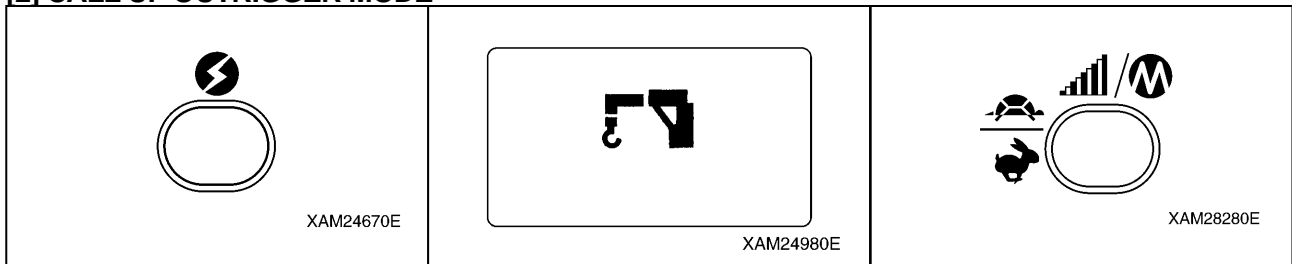

1. Push the Power button to turn ON the Transmitter.
2. The "Crane mark" is displayed in the LCD screen for about 2 seconds.
3. While the "Crane mark" is displayed, push the speed button for about 2 seconds. The LCD provides the screen for selecting "CRANE MODE" or "OUTRIGGER MODE".

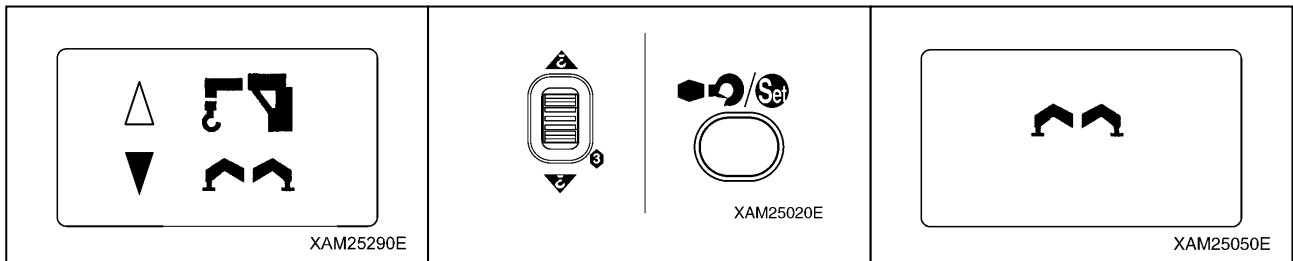

4. Use the Hook raising and lowering Lever to shift the cursor (▲ or ▼), and push the Setting button when the cursor points to the "OUTRIGGER".

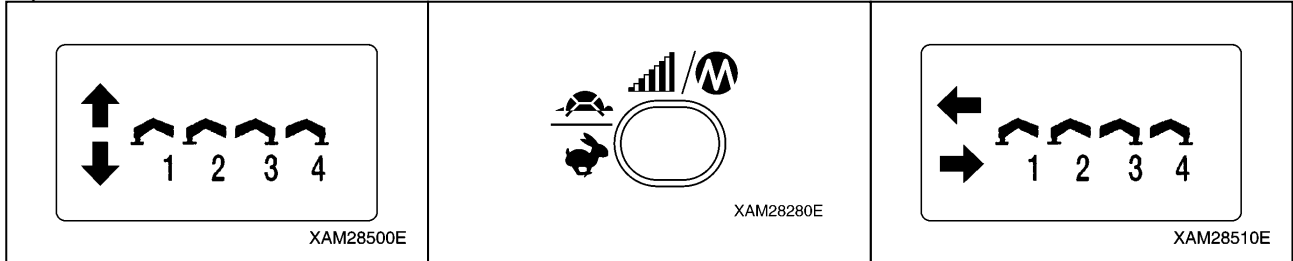

5. The operation mode is already switched to the "OUTRIGGER MODE", thus the "Outrigger mark" is exhibited. Soon after, it enters into "Ground setting mode", then the mark turns to "Ground setting (▲ ▼)".

6. To shift to "Extension mode", push the Speed/Mode button, while the LCD screen shows the "Ground setting mode". Then the mode is switched to "Extension mode"; the mark turns to "Extension (◀ ▶)".

8.2 OPERATION IN OUTRIGGER MODE

The outriggers of the crane are numbered from 1 to 4 and these correspond to the numbers of each operation lever on the remote control.

If you want to START any action, always use the operation lever first and only afterwards pull the accelerator (slowly).

If you want to END any action, first release the accelerator slowly, and then release the operation lever.

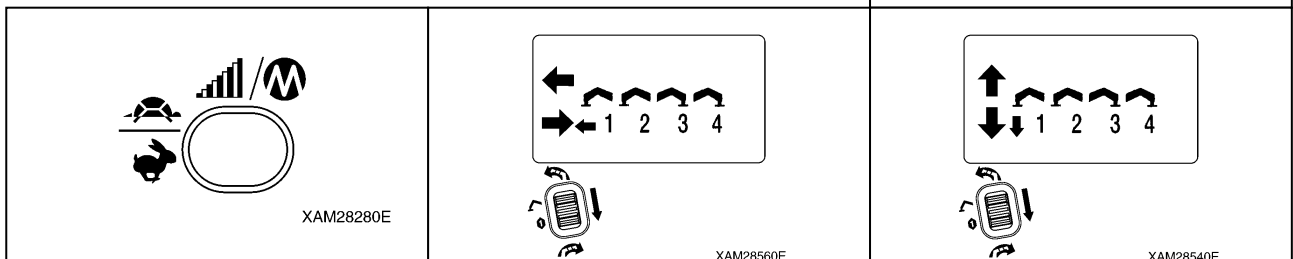
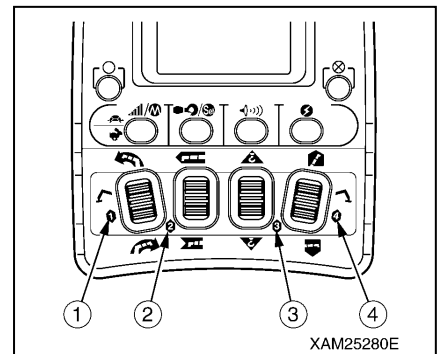

1. Push Speed/Mode button, the operation mode is switched to "Outrigger Extension mode".
2. Turn one of the outrigger operation levers to "Extend (lower)"
(Extend the outriggers (by pushing down the levers) as much as possible)
3. Push Speed/Mode button, the operation mode is switched to "Ground setting mode".
4. Put the outriggers down ONE by ONE (by pushing down the levers) until they all just touch the ground.
5. Then use the outriggers TWO by TWO to stabilize the crane.
6. Check the bubble in the level in order to make sure the crane is in the correct position.
7. Make sure the rubber tracks are about 50mm above the ground.

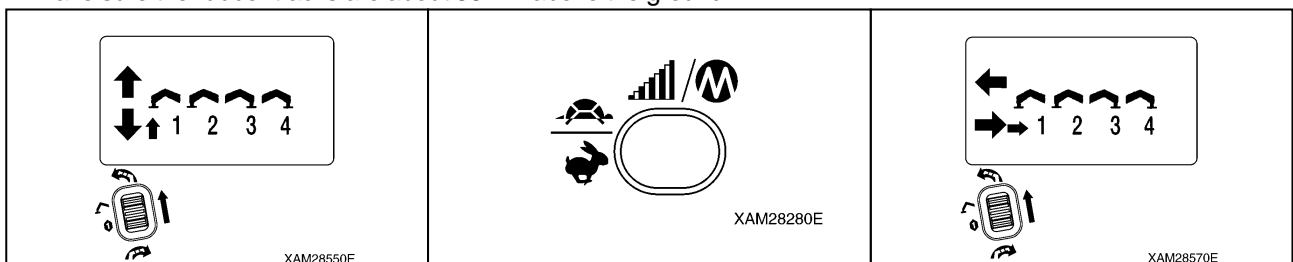

For stowing the outriggers: push the operation levers up.

8.3 OPERATION IN CRANE MODE

Four Crane operation switches are provided. Each controls the following operation, respectively. (See the figure on the right.)

- (1): Slewing (upper: counterclockwise, lower: clockwise)
- (2): Boom telescoping (upper: extend, lower: retract)
- (3): Hook raising and lowering (upper: raising, lower: lowering)
- (4): Boom derricking (upper: raising, lower: lowering)

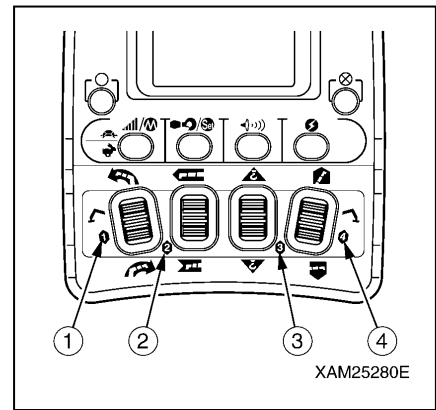

8.4 AUTOMATIC HOOK STOW FUNCTION

NOTES

This automatic hook stow function is not available in the "Micro Speed mode" or "Enhanced Speed mode". To stow the hook, always cancel either the "Micro Speed mode" or "Enhanced Speed mode". For the speed modes, please see 8.5. Set up and Cancel Micro Speed

1. Configure the boom to the travelling condition and push the Hook raising and lowering/No.2 outrigger operation lever to "Raise (upper)", then pull the Accelerator lever. Keep raising the hook until it touches to the over-hoist detector weight and automatically stops.
2. When the hook automatically stops, push the Hook stow/Setting button. LCD screen in the Transmitter displays "HOOK I".
3. Keep pushing the Hook stow/Setting button, pull the Accelerator lever slowly. The hook will be raised to the proper stow position. (Stop this operation once the hook block touches the boom.)

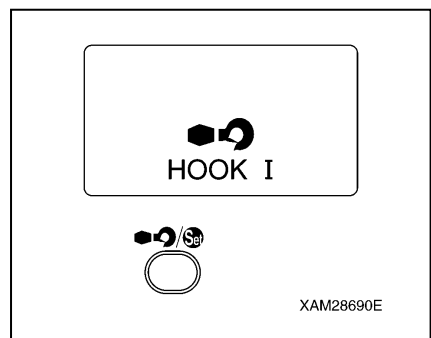

8.5 SET-UP AND CANCEL MICRO SPEED

The speed of the crane can also be controlled by the MICRO SPEED MODE. Just push the speed/mode button and each push will forward the LCD screen indication as shown in the diagram to the right.

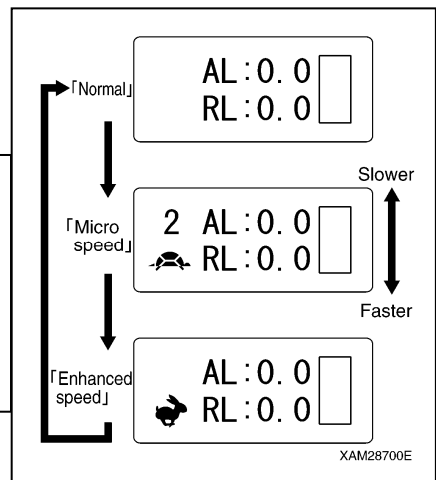
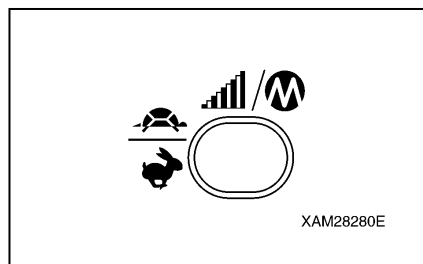

9. ELECTRIC MOTOR

If electric motor is required, please attach a electric cable and turn the engine and electric motor switch to the "Electric Motor" (right) position. To start the electric motor, simply insert the key into the main starter switch and turn on the engine. (Pre-heating is not necessary.)

All other operations (travelling – outriggers – crane) are the same as described in previous chapters.

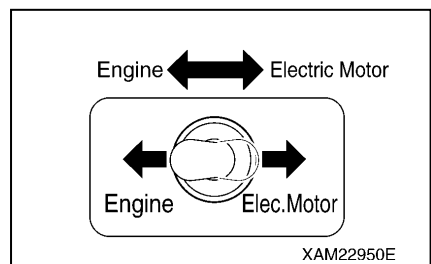

MAEDA MINI-CRAWLER CRANE MC-305-2C QUICK OPERATION GUIDE

Document No: 103E-OG0907-00

First edition: July 31, 2009

Issued by Maeda Seisakusyo Co., Ltd.
1095 Onbegawa, Shinonoi
Nagano, Nagano 388-8522,
Japan

No part of this manual can be reproduced in any form without permission